

REVISIONS	
NO.	BY
Δ	
Δ	
Δ	

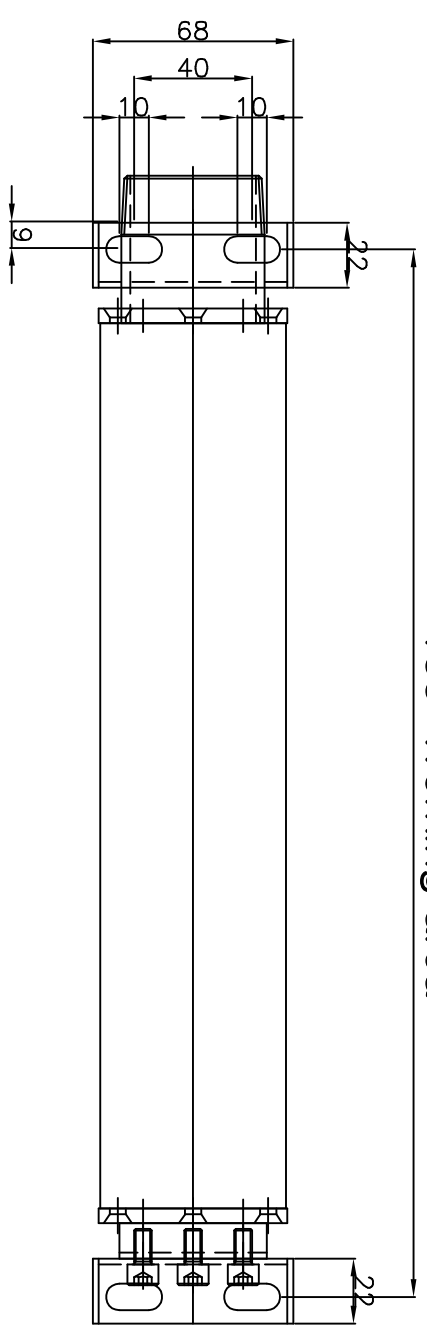

155+Working area

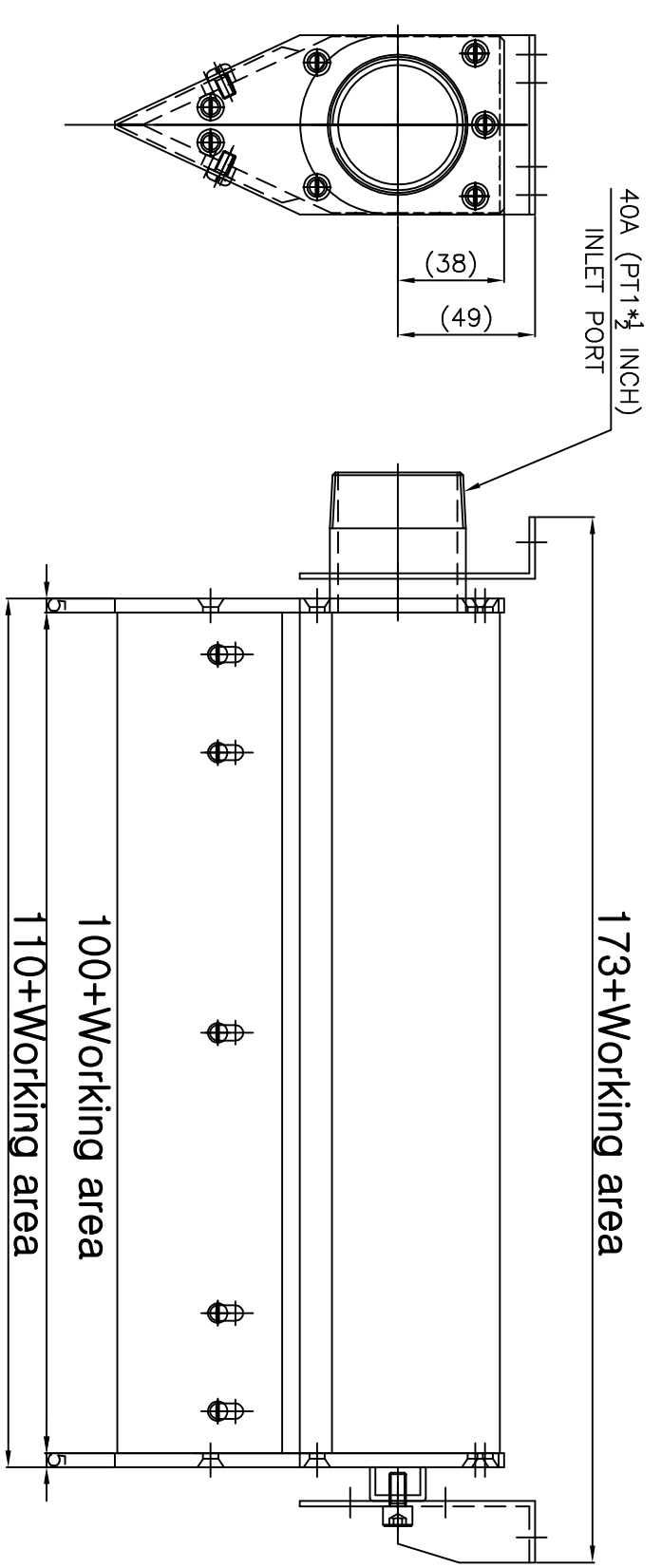

173+Working area

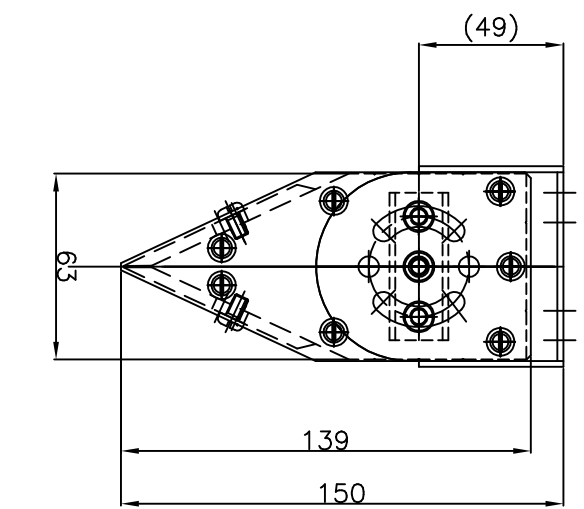

Length : M^a f100mm X M^Q1 f 4800mm

NOTE

1. Remove burrs at curb
2. Tolerance between bolt holes is ±0.2

COMMERCIAL TOLERANCE(mm)		COMPARISON OF SURFACE ROUGHNESS	
MACHINING	TOL.	CANNING	TOL.
4-16	±0.1	100-200	±1.6
18-48	±0.2	200-500	±3.2
60-120	±0.3	500-1000	±6.3
250-1000	±0.8	1000-2000	±12.5
1000-2000	±1.0	4000-8000	±40.0
2000-3000	±1.5		

NO	DESCRIPTION	SPECIFICATION	Q'TY	MATER'L	WEIGHT	REMARKS
DATE	2021.04	SCALE 1 / 1				
DRAWN BY	DESIGNED BY	CHECKED BY	APPROVED BY	CUSTOMER		
TITLE				PAB-ALA0-L-1-S1-BK		
HEAT TREATMENT				AIR KNIFE ASS'Y		
DRAWING NO.				MBA-25A-000		



5 A4594X420 (SCALE 1:1)